

- = CARPETED AREA
- ⊕ = EXTERIOR RECEPTACLE
- HB ⊕ = EXTERIOR HOSE BIBB
- ⊕ = FLUSH MOUNT RECESSED-STYLE LIGHT
- ⊙ = CEILING LIGHT

ALL IMAGES ARE FOR ARTISTIC PURPOSES ONLY AND MAY CONTAIN ADDITIONAL FEATURES OR DESIGN OPTIONS NOT AVAILABLE ON ALL HOME PLANS AND IN ALL NEIGHBORHOODS. ROOM SIZE DIMENSIONS AND SQUARE FOOTAGES ARE APPROXIMATE. CONTACT SALES AGENT FOR MORE INFORMATION. TERMS AND CONDITIONS APPLY.  
[HTTPS://EGStoltzfus.com/terms-and-conditions/](https://EGStoltzfus.com/terms-and-conditions/)

PDF LAST UPDATED 4/1/2024

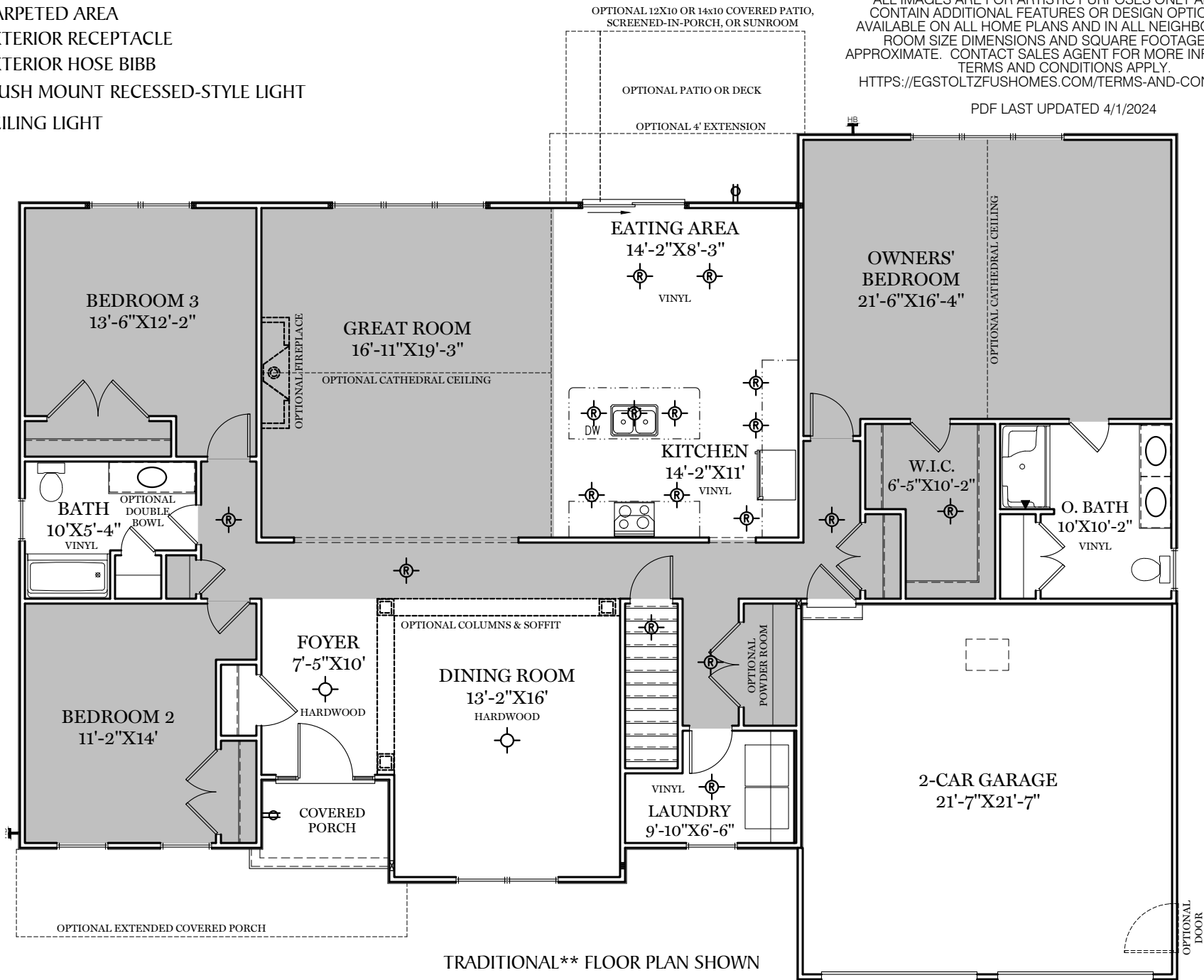

TRADITIONAL\*\* FLOOR PLAN SHOWN

# 1st Floor Plan - 2,357 sf

WELLINGTON

\*\* TRADITIONAL FLOOR PLAN ONLY AVAILABLE IN SELECT COMMUNITIES

ALL IMAGES ARE FOR ARTISTIC PURPOSES ONLY AND MAY CONTAIN ADDITIONAL FEATURES OR DESIGN OPTIONS NOT AVAILABLE ON ALL HOME PLANS AND IN ALL NEIGHBORHOODS. ROOM SIZE DIMENSIONS AND SQUARE FOOTAGES ARE APPROXIMATE. CONTACT SALES AGENT FOR MORE INFORMATION. TERMS AND CONDITIONS APPLY.  
[HTTPS://EGSTOLTZFUSHOMES.COM/TERMS-AND-CONDITIONS/](https://EGSTOLTZFUSHOMES.COM/TERMS-AND-CONDITIONS/)

PDF LAST UPDATED 4/1/2024

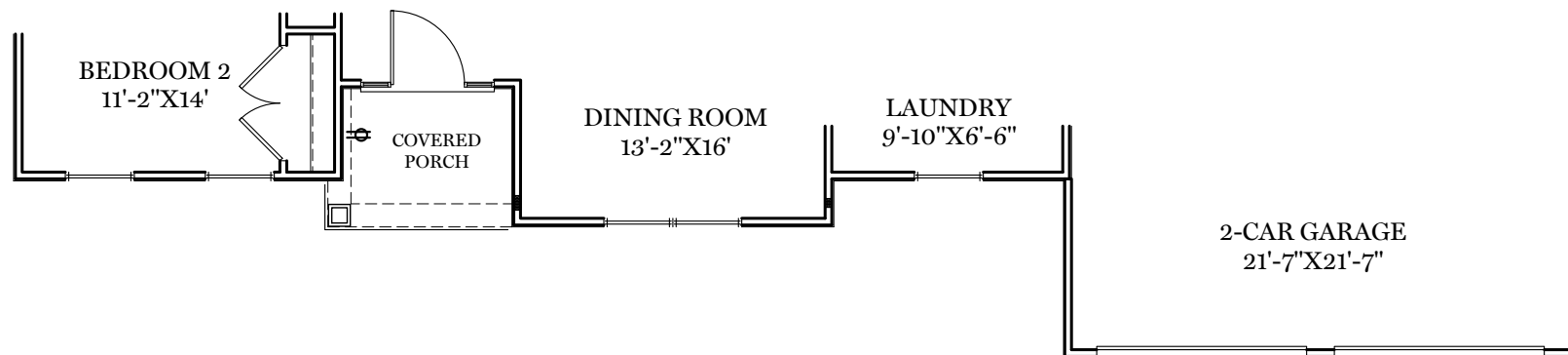

CLASSIC, AMERICAN, & HERITAGE FLOOR PLAN

⊕ = FLUSH MOUNT RECESSED-STYLE LIGHT

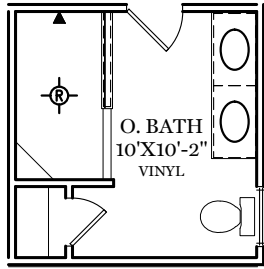

OPTIONAL LUXURY BATH

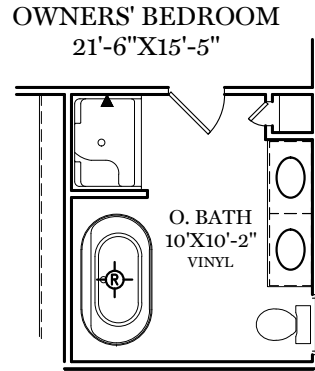

OPTIONAL RETREAT BATH

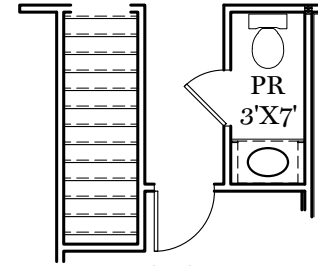

OPTIONAL POWDER ROOM

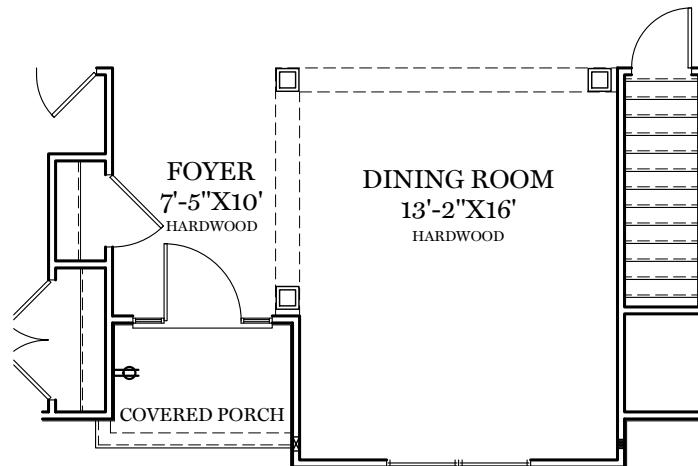

OPTIONAL COLUMNS & SOFFIT

ALL IMAGES ARE FOR ARTISTIC PURPOSES ONLY AND MAY CONTAIN ADDITIONAL FEATURES OR DESIGN OPTIONS NOT AVAILABLE ON ALL HOME PLANS AND IN ALL NEIGHBORHOODS. ROOM SIZE DIMENSIONS AND SQUARE FOOTAGES ARE APPROXIMATE. CONTACT SALES AGENT FOR MORE INFORMATION. TERMS AND CONDITIONS APPLY. [HTTPS://EGSTOLTZFUSHOMES.COM/TERMS-AND-CONDITIONS/](https://EGSTOLTZFUSHOMES.COM/TERMS-AND-CONDITIONS/)

INCLUDES ADDITIONAL  
EXTERIOR RECEPTACLE

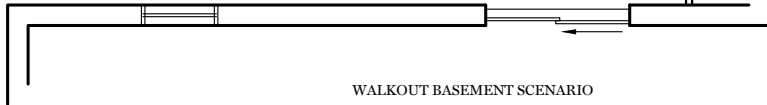

WALKOUT BASEMENT SCENARIO

ALL IMAGES ARE FOR ARTISTIC PURPOSES ONLY AND MAY  
CONTAIN ADDITIONAL FEATURES OR DESIGN OPTIONS NOT  
AVAILABLE ON ALL HOME PLANS AND IN ALL NEIGHBORHOODS.  
ROOM SIZE DIMENSIONS AND SQUARE FOOTAGES ARE  
APPROXIMATE. CONTACT SALES AGENT FOR MORE INFORMATION.  
TERMS AND CONDITIONS APPLY.  
[HTTPS://EGSTOLTZFUSHOMES.COM/TERMS-AND-CONDITIONS/](https://EGSTOLTZFUSHOMES.COM/TERMS-AND-CONDITIONS/)

PDF LAST UPDATED 4/1/2024

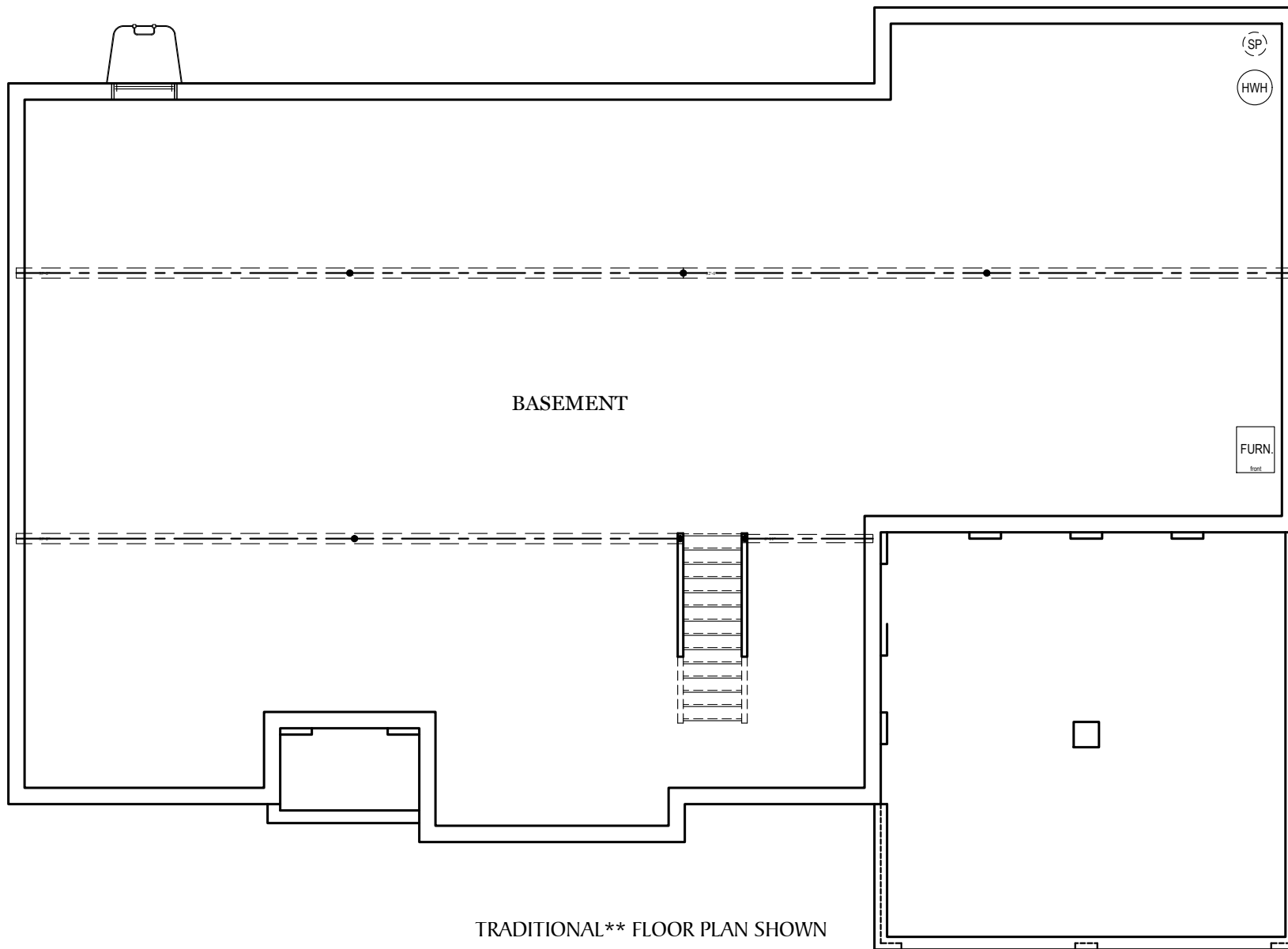

BASEMENT

(SP)  
HWH

FURN.  
front

TRADITIONAL\*\* FLOOR PLAN SHOWN

# Foundation

WELLINGTON



\*\* TRADITIONAL FLOOR  
PLAN ONLY AVAILABLE IN  
SELECT COMMUNITIES

E.G.S. RESERVES THE RIGHT TO  
RELOCATE MECHANICALS AS REQ.  
BY SITE CONDITIONS

■ = CARPETED AREA

⊗ = FLUSH MOUNT RECESSED-STYLE LIGHT

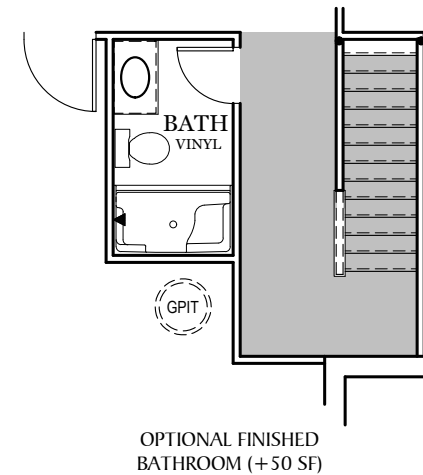
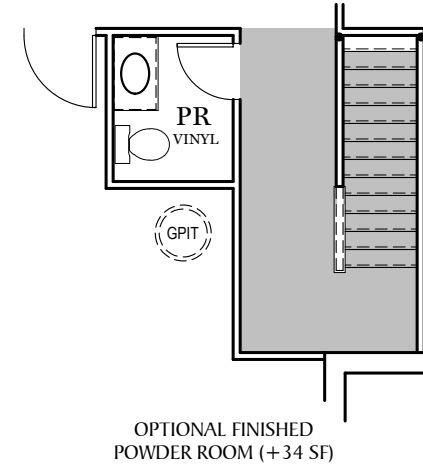
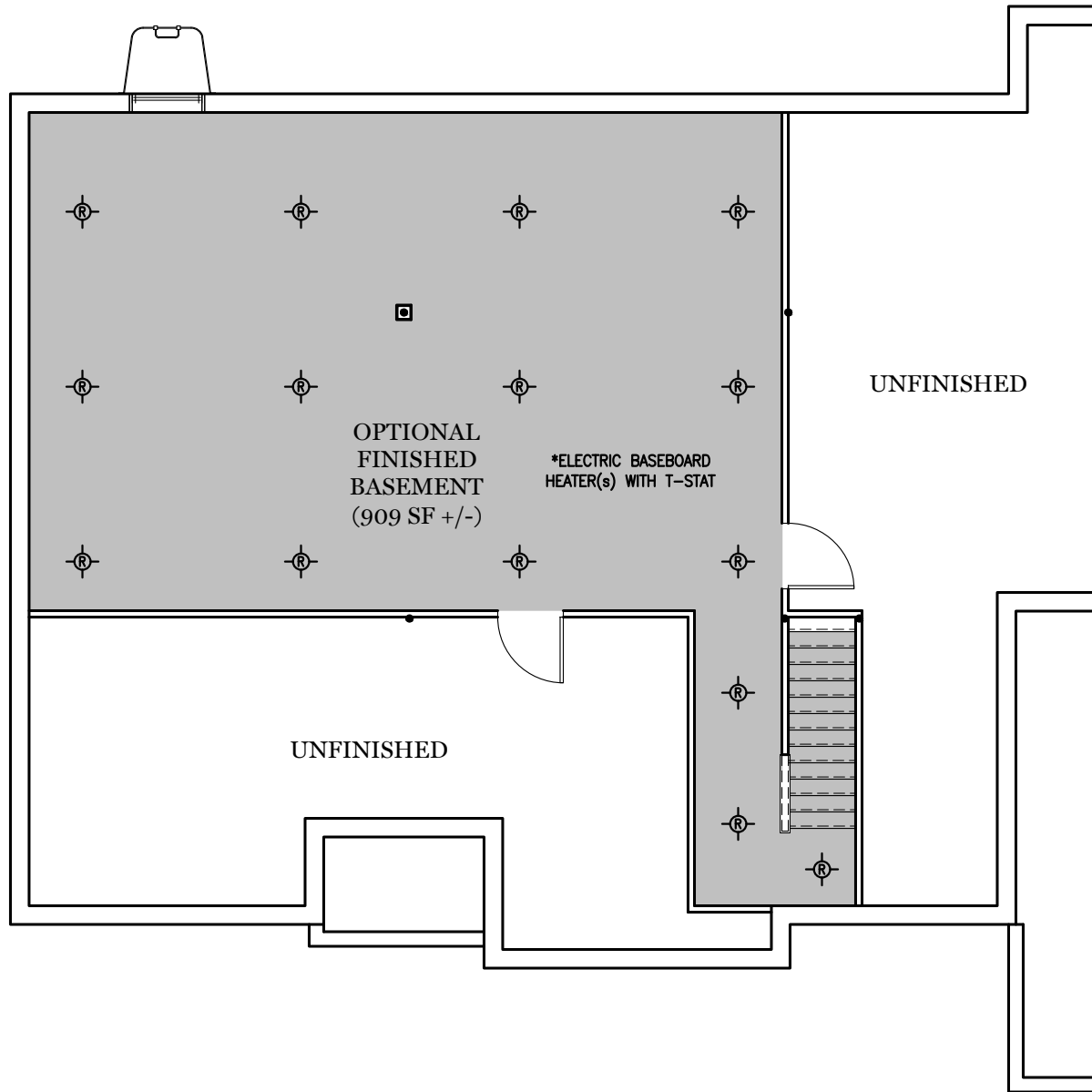

ALL IMAGES ARE FOR ARTISTIC PURPOSES ONLY AND MAY CONTAIN ADDITIONAL FEATURES OR DESIGN OPTIONS NOT AVAILABLE ON ALL HOME PLANS AND IN ALL NEIGHBORHOODS. ROOM SIZE DIMENSIONS AND SQUARE FOOTAGES ARE APPROXIMATE. CONTACT SALES AGENT FOR MORE INFORMATION. TERMS AND CONDITIONS APPLY. [HTTPS://EGSTOLTZFUSHOMES.COM/TERMS-AND-CONDITIONS/](https://EGSTOLTZFUSHOMES.COM/TERMS-AND-CONDITIONS/)



OPTIONAL EXTENDED COVERED PORCH



TRADITIONAL ELEVATION\*\*



OPTIONAL EXTENDED COVERED PORCH



CLASSIC ELEVATION



OPTIONAL EXTENDED COVERED PORCH



AMERICAN ELEVATION



OPTIONAL EXTENDED COVERED PORCH



HERITAGE ELEVATION

ALL IMAGES ARE FOR ARTISTIC PURPOSES ONLY AND MAY CONTAIN ADDITIONAL FEATURES OR DESIGN OPTIONS NOT AVAILABLE ON ALL HOME PLANS AND IN ALL NEIGHBORHOODS. ROOM SIZE DIMENSIONS AND SQUARE FOOTAGES ARE APPROXIMATE. CONTACT SALES AGENT FOR MORE INFORMATION. TERMS AND CONDITIONS APPLY. [HTTPS://EGSTOLTZFUSHOMES.COM/TERMS-AND-CONDITIONS/](https://EGSTOLTZFUSHOMES.COM/TERMS-AND-CONDITIONS/)