







-  = CARPETED AREA
-  = CABLE T.V. ROUGH IN
-  = EXTERIOR RECEPTACLE
-  = RECEPTACLE WITH USB
-  = TELEPHONE OUTLET
-  = EXTERIOR HOSE BIBB



TRADITIONAL\*\* FLOOR PLAN SHOWN

# 1st Floor Plan - 1,320 sf

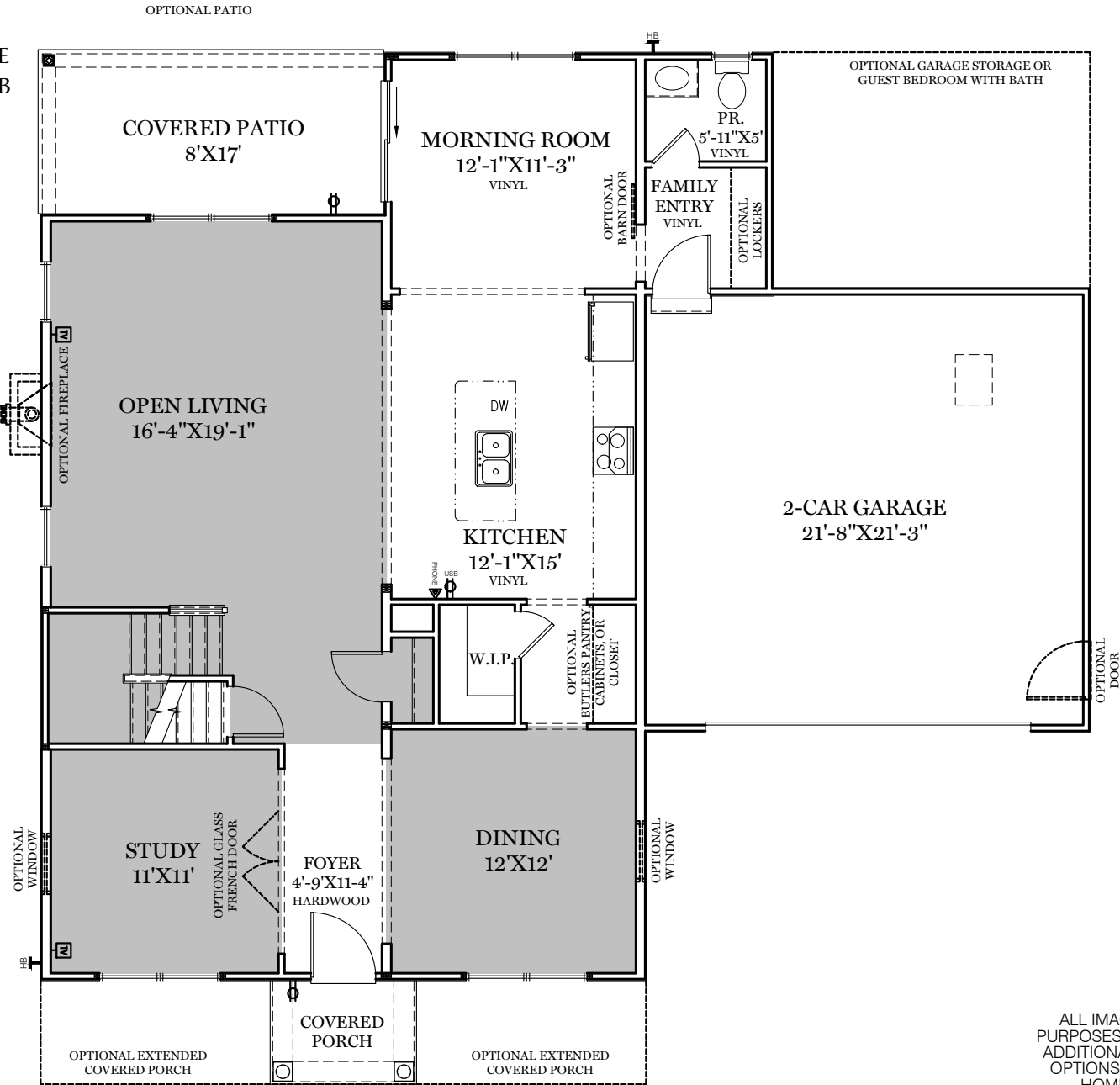
"GLEN MARY"

ALL IMAGES ARE FOR ARTISTIC PURPOSES ONLY AND MAY CONTAIN ADDITIONAL FEATURES OR DESIGN OPTIONS NOT AVAILABLE ON ALL HOME PLANS AND IN ALL NEIGHBORHOODS. ROOM SIZE DIMENSIONS AND SQUARE FOOTAGES ARE APPROXIMATE. CONTACT SALES AGENT FOR MORE INFORMATION. TERMS AND CONDITIONS APPLY. [HTTPS://EGSTOLTZFUSHOMES.COM/TERMS-AND-CONDITIONS/](https://EGSTOLTZFUSHOMES.COM/TERMS-AND-CONDITIONS/)

\*\* TRADITIONAL FLOOR PLAN ONLY AVAILABLE IN SELECT COMMUNITIES

PDF LAST UPDATED 10/08/2021

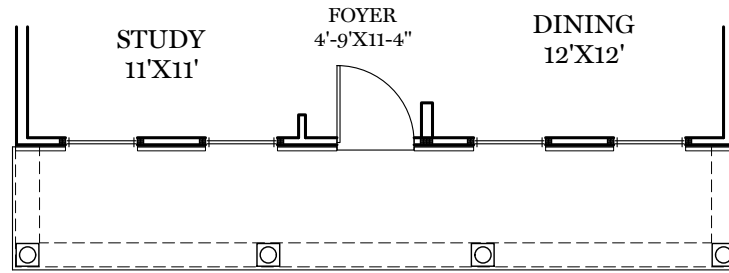

CLASSIC FLOOR PLAN

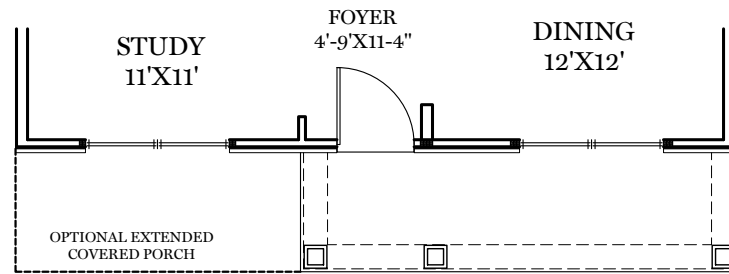

AMERICAN FLOOR PLAN

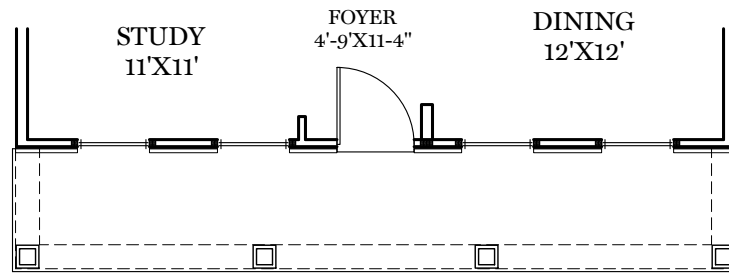

HERITAGE FLOOR PLAN

# 1st Floor Plan

"GLEN MARY"

ALL IMAGES ARE FOR ARTISTIC PURPOSES ONLY AND MAY CONTAIN ADDITIONAL FEATURES OR DESIGN OPTIONS NOT AVAILABLE ON ALL HOME PLANS AND IN ALL NEIGHBORHOODS. ROOM SIZE DIMENSIONS AND SQUARE FOOTAGES ARE APPROXIMATE. CONTACT SALES AGENT FOR MORE INFORMATION. TERMS AND CONDITIONS APPLY. [HTTPS://EGSTOLTZFUSHOMES.COM/TERMS-AND-CONDITIONS/](https://EGSTOLTZFUSHOMES.COM/TERMS-AND-CONDITIONS/)

PDF LAST UPDATED 10/08/2021

= CARPETED AREA  
 = CABLE T.V. ROUGH IN

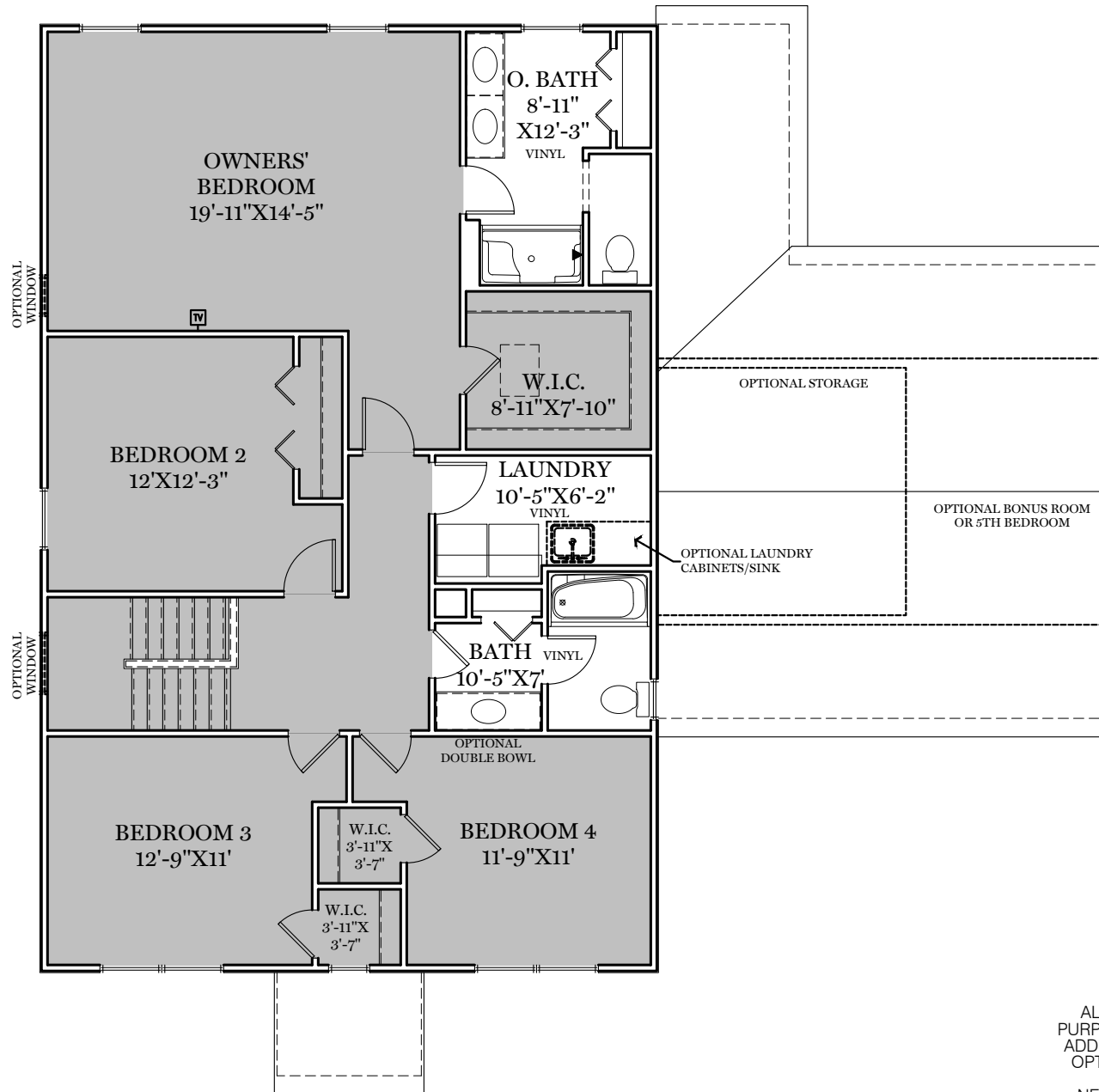

TRADITIONAL\*\* FLOOR PLAN SHOWN

## 2nd Floor Plan - 1,380 sf

"GLEN MARY"

\*\* TRADITIONAL FLOOR PLAN ONLY AVAILABLE IN SELECT COMMUNITIES

ALL IMAGES ARE FOR ARTISTIC PURPOSES ONLY AND MAY CONTAIN ADDITIONAL FEATURES OR DESIGN OPTIONS NOT AVAILABLE ON ALL HOME PLANS AND IN ALL NEIGHBORHOODS. ROOM SIZE DIMENSIONS AND SQUARE FOOTAGES ARE APPROXIMATE. CONTACT SALES AGENT FOR MORE INFORMATION. TERMS AND CONDITIONS APPLY. [HTTPS://EGSTOLTZFUSHOMES.COM/TERMS-AND-CONDITIONS/](https://EGSTOLTZFUSHOMES.COM/TERMS-AND-CONDITIONS/)

PDF LAST UPDATED 10/08/2021

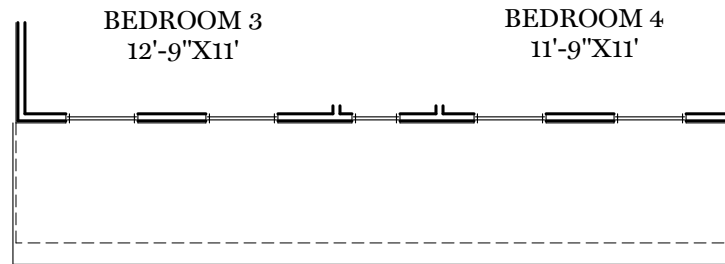

CLASSIC FLOOR PLAN

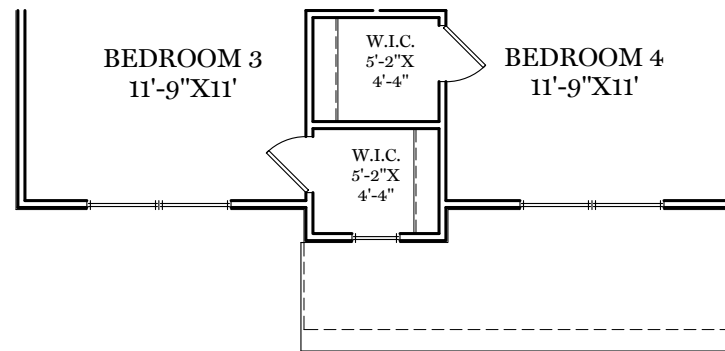

AMERICAN FLOOR PLAN

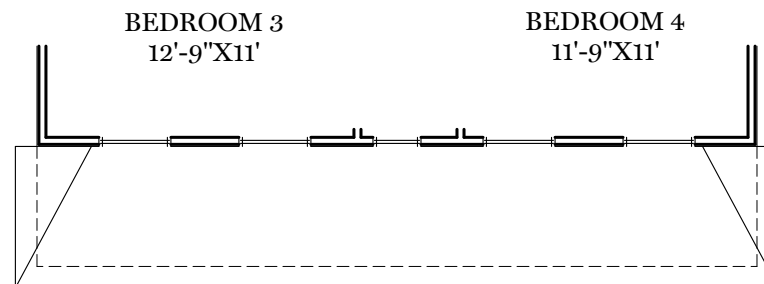

HERITAGE FLOOR PLAN

## 2nd Floor Plan

"GLEN MARY"

ALL IMAGES ARE FOR ARTISTIC PURPOSES ONLY AND MAY CONTAIN ADDITIONAL FEATURES OR DESIGN OPTIONS NOT AVAILABLE ON ALL HOME PLANS AND IN ALL NEIGHBORHOODS. ROOM SIZE DIMENSIONS AND SQUARE FOOTAGES ARE APPROXIMATE. CONTACT SALES AGENT FOR MORE INFORMATION. TERMS AND CONDITIONS APPLY. [HTTPS://EGSTOLTZFUSHOMES.COM/TERMS-AND-CONDITIONS/](https://EGSTOLTZFUSHOMES.COM/TERMS-AND-CONDITIONS/)

PDF LAST UPDATED 10/08/2021

■ = CARPETED AREA



ENLARGED FIRST FLOOR LIVING AREA OPTION 2  
(REQUIRED ON FULL/PARTIAL DAYLIGHT LOTS)

OPTIONAL PATIO OR DECK

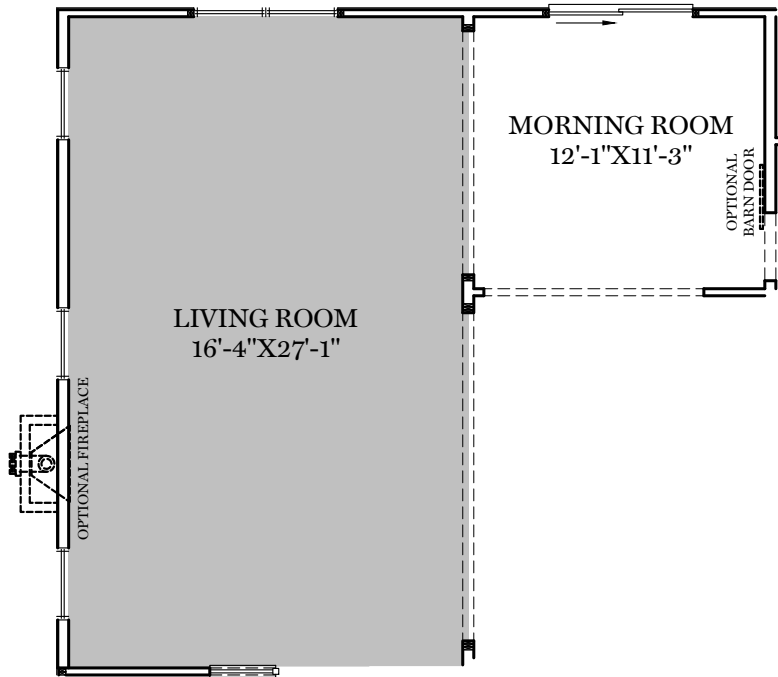

ENLARGED FIRST FLOOR LIVING AREA OPTION 1  
(REQUIRED ON FULL/PARTIAL DAYLIGHT LOTS)

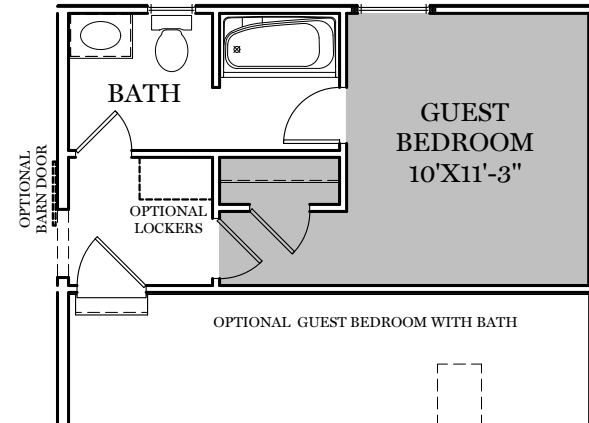
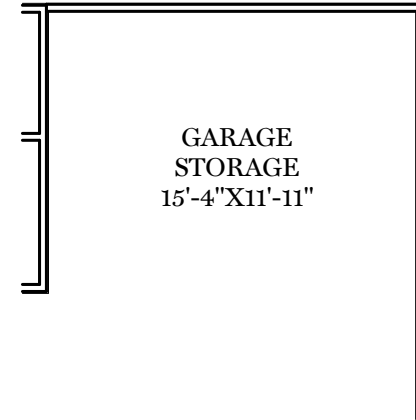

ALL IMAGES ARE FOR ARTISTIC PURPOSES ONLY AND MAY CONTAIN ADDITIONAL FEATURES OR DESIGN OPTIONS NOT AVAILABLE ON ALL HOME PLANS AND IN ALL NEIGHBORHOODS. ROOM SIZE DIMENSIONS AND SQUARE FOOTAGES ARE APPROXIMATE. CONTACT SALES AGENT FOR MORE INFORMATION. TERMS AND CONDITIONS APPLY. [HTTPS://EGSTOLTZFUSHOMES.COM/TERMS-AND-CONDITIONS/](https://egstoltzfushomes.com/terms-and-conditions/)

■ = CARPETED AREA

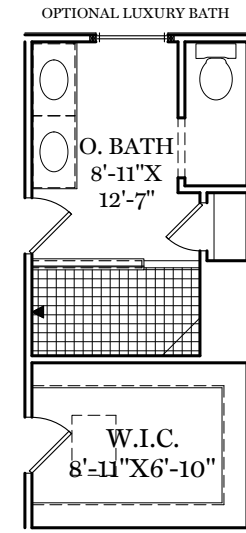
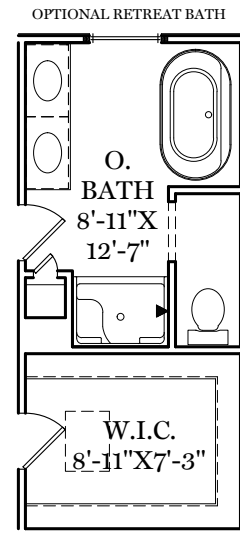
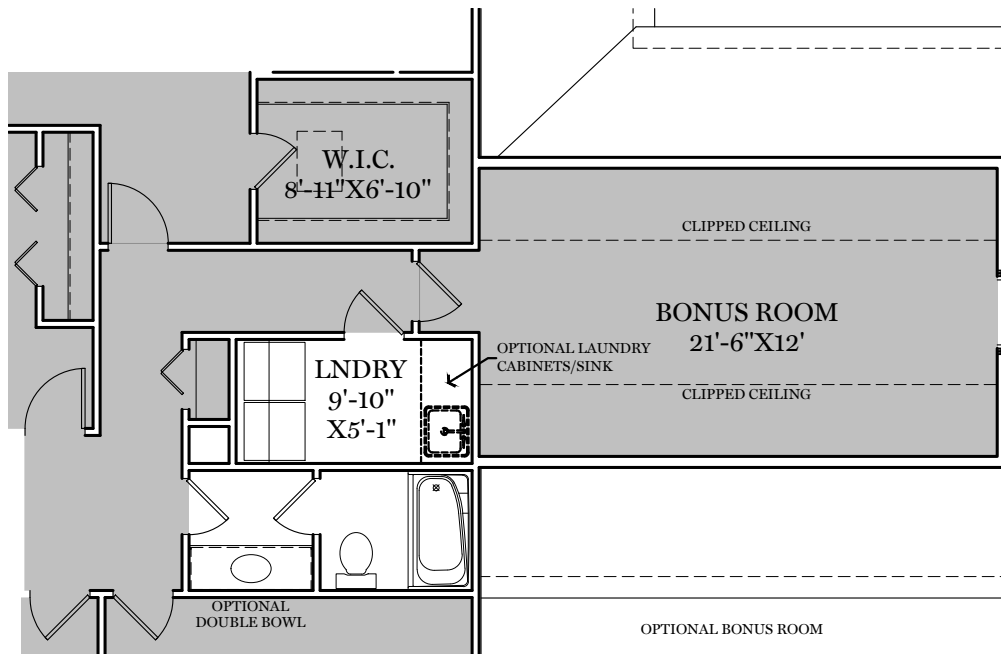
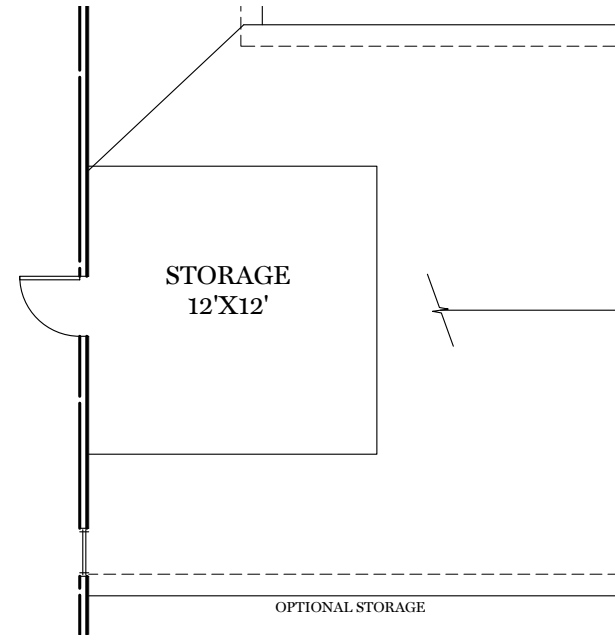
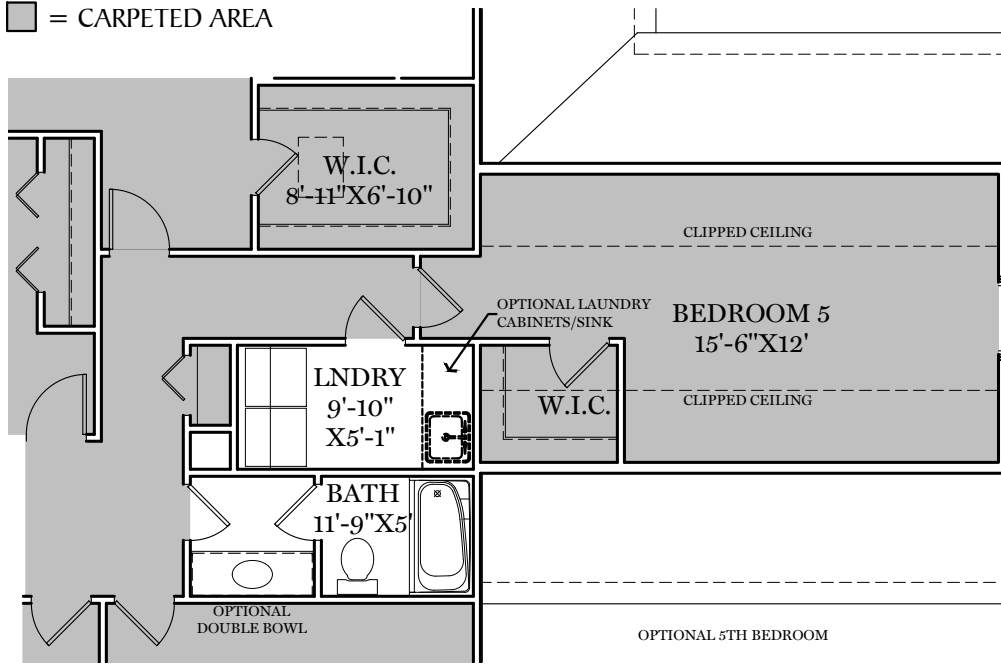

ALL IMAGES ARE FOR ARTISTIC PURPOSES ONLY AND MAY CONTAIN ADDITIONAL FEATURES OR DESIGN OPTIONS NOT AVAILABLE ON ALL HOME PLANS AND IN ALL NEIGHBORHOODS. ROOM SIZE DIMENSIONS AND SQUARE FOOTAGES ARE APPROXIMATE. CONTACT SALES AGENT FOR MORE INFORMATION. TERMS AND CONDITIONS APPLY. [HTTPS://EGSTOLTZFUSHOMES.COM/TERMS-AND-CONDITIONS/](https://EGSTOLTZFUSHOMES.COM/TERMS-AND-CONDITIONS/)

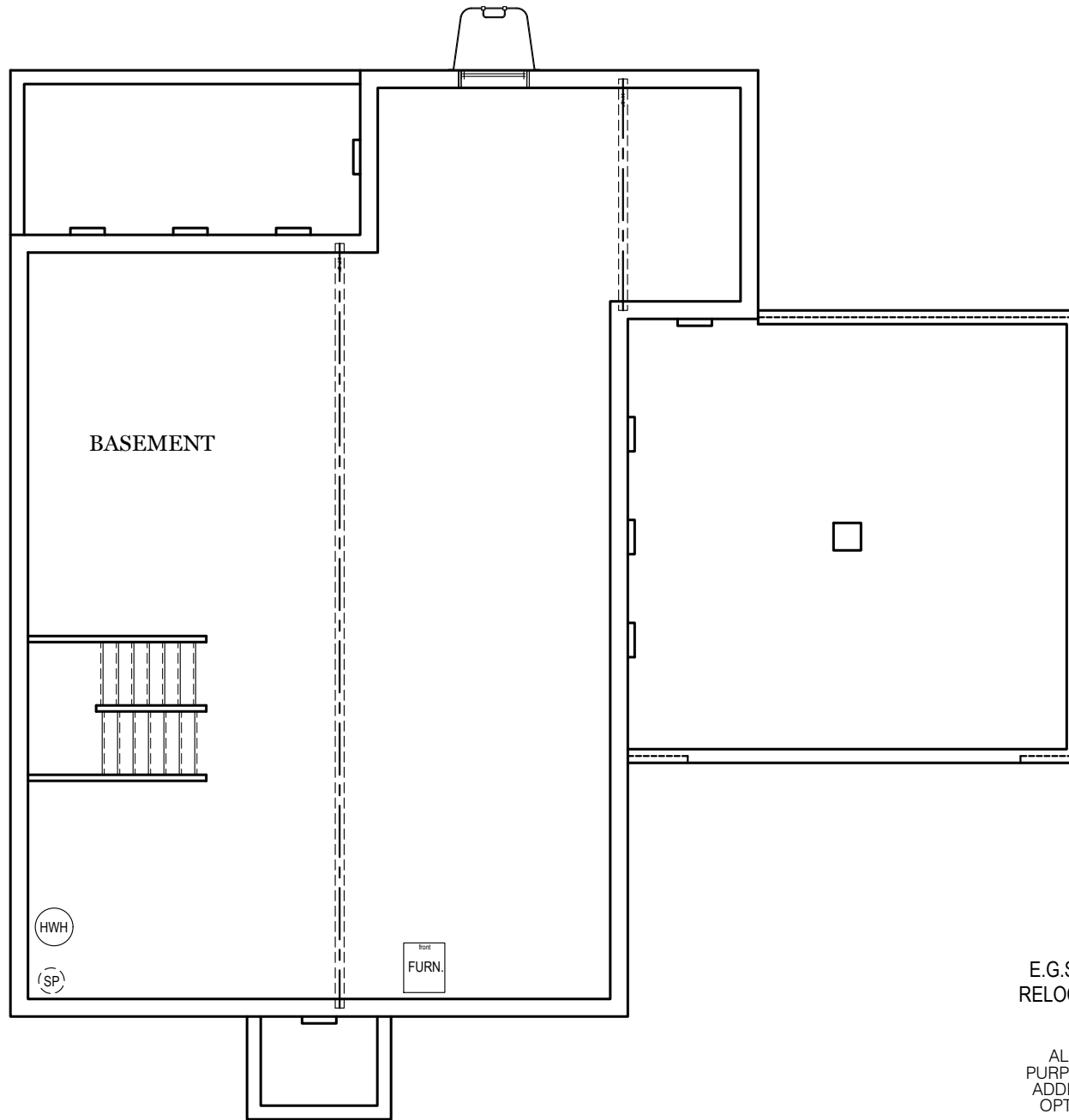

TRADITIONAL\*\* FLOOR PLAN SHOWN

# Foundation

"GLEN MARY"

E.G.S. RESERVES THE RIGHT TO RELOCATE MECHANICALS AS REQ. BY SITE CONDITIONS

ALL IMAGES ARE FOR ARTISTIC PURPOSES ONLY AND MAY CONTAIN ADDITIONAL FEATURES OR DESIGN OPTIONS NOT AVAILABLE ON ALL HOME PLANS AND IN ALL NEIGHBORHOODS. ROOM SIZE DIMENSIONS AND SQUARE FOOTAGES ARE APPROXIMATE. CONTACT SALES AGENT FOR MORE INFORMATION. TERMS AND CONDITIONS APPLY. [HTTPS://EGSTOLTZFUSHOMES.COM/TERMS-AND-CONDITIONS/](https://EGSTOLTZFUSHOMES.COM/TERMS-AND-CONDITIONS/)

\*\* TRADITIONAL FLOOR PLAN ONLY AVAILABLE IN SELECT COMMUNITIES

PDF LAST UPDATED 10/08/2021

WALKOUT BASEMENT SCENARIO

INCLUDES ADDITIONAL  
EXTERIOR RECEPTACLE

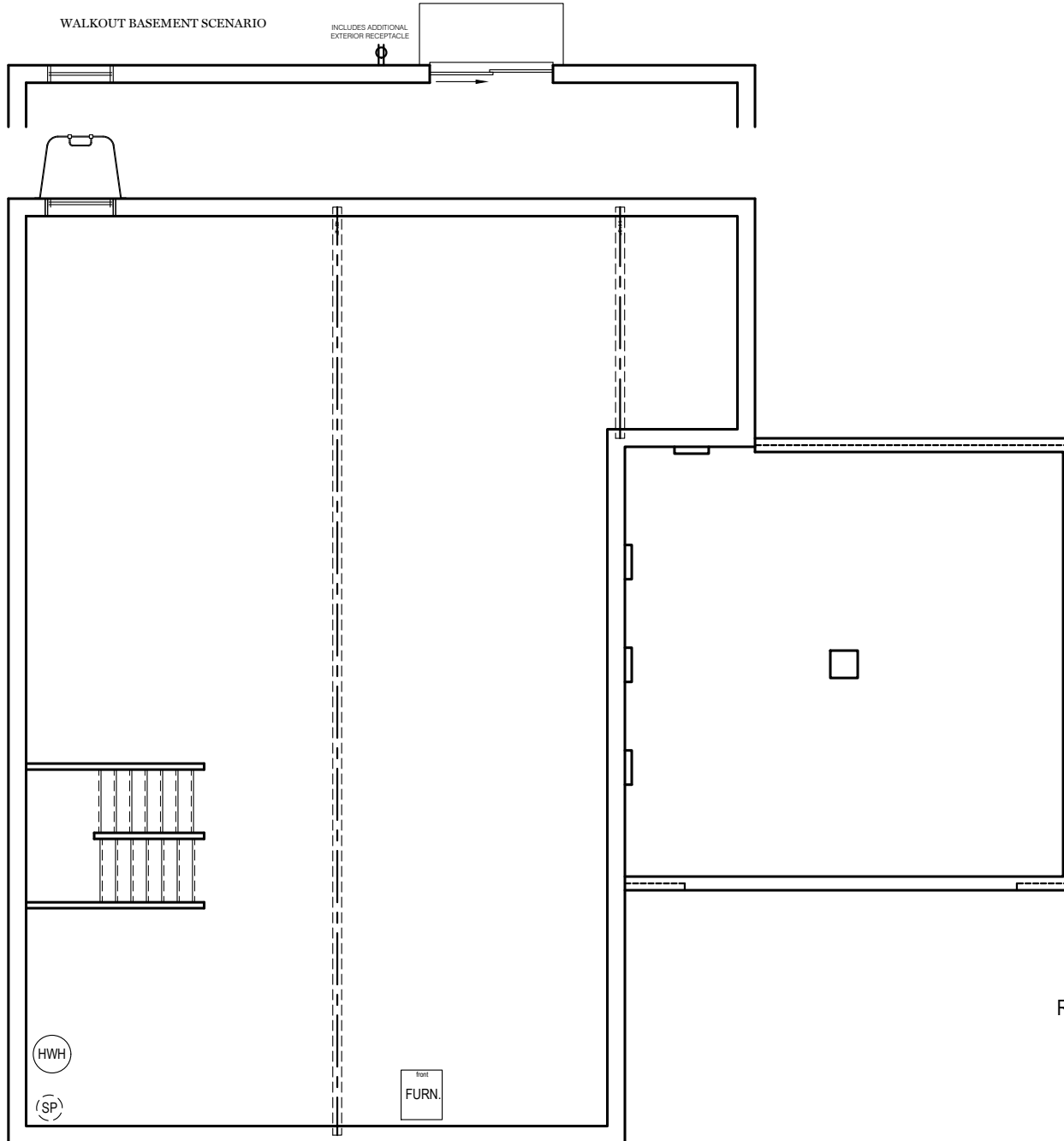

FOUNDATION FOR OPEN LIVING OPTION SHOWN

# Foundation

"GLEN MARY"

E.G.S. RESERVES THE RIGHT TO  
RELOCATE MECHANICALS AS REQ.  
BY SITE CONDITIONS

ALL IMAGES ARE FOR ARTISTIC  
PURPOSES ONLY AND MAY CONTAIN  
ADDITIONAL FEATURES OR DESIGN  
OPTIONS NOT AVAILABLE ON ALL  
HOME PLANS AND IN ALL  
NEIGHBORHOODS. ROOM SIZE  
DIMENSIONS AND SQUARE FOOTAGES  
ARE APPROXIMATE. CONTACT SALES  
AGENT FOR MORE INFORMATION.  
TERMS AND CONDITIONS APPLY.  
[HTTPS://EGSTOLTZFUSHOMES.COM/  
TERMS-AND-CONDITIONS/](https://EGSTOLTZFUSHOMES.COM/TERMS-AND-CONDITIONS/)

PDF LAST UPDATED 10/08/2021



**EGStoltzfus**

BUILDING ONE STORY AT A TIME



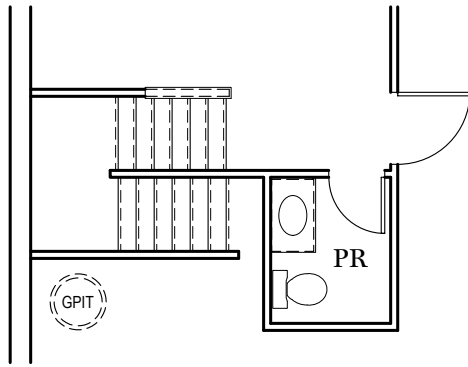

OPTIONAL FINISHED  
POWDER ROOM

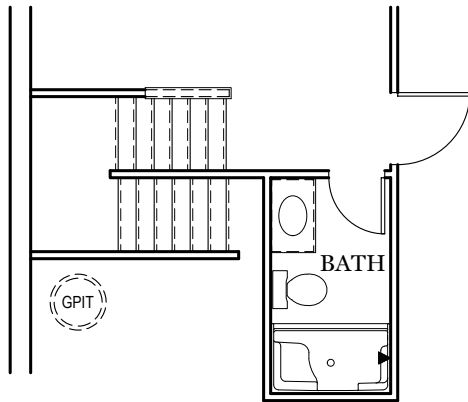

OPTIONAL FINISHED  
BATHROOM

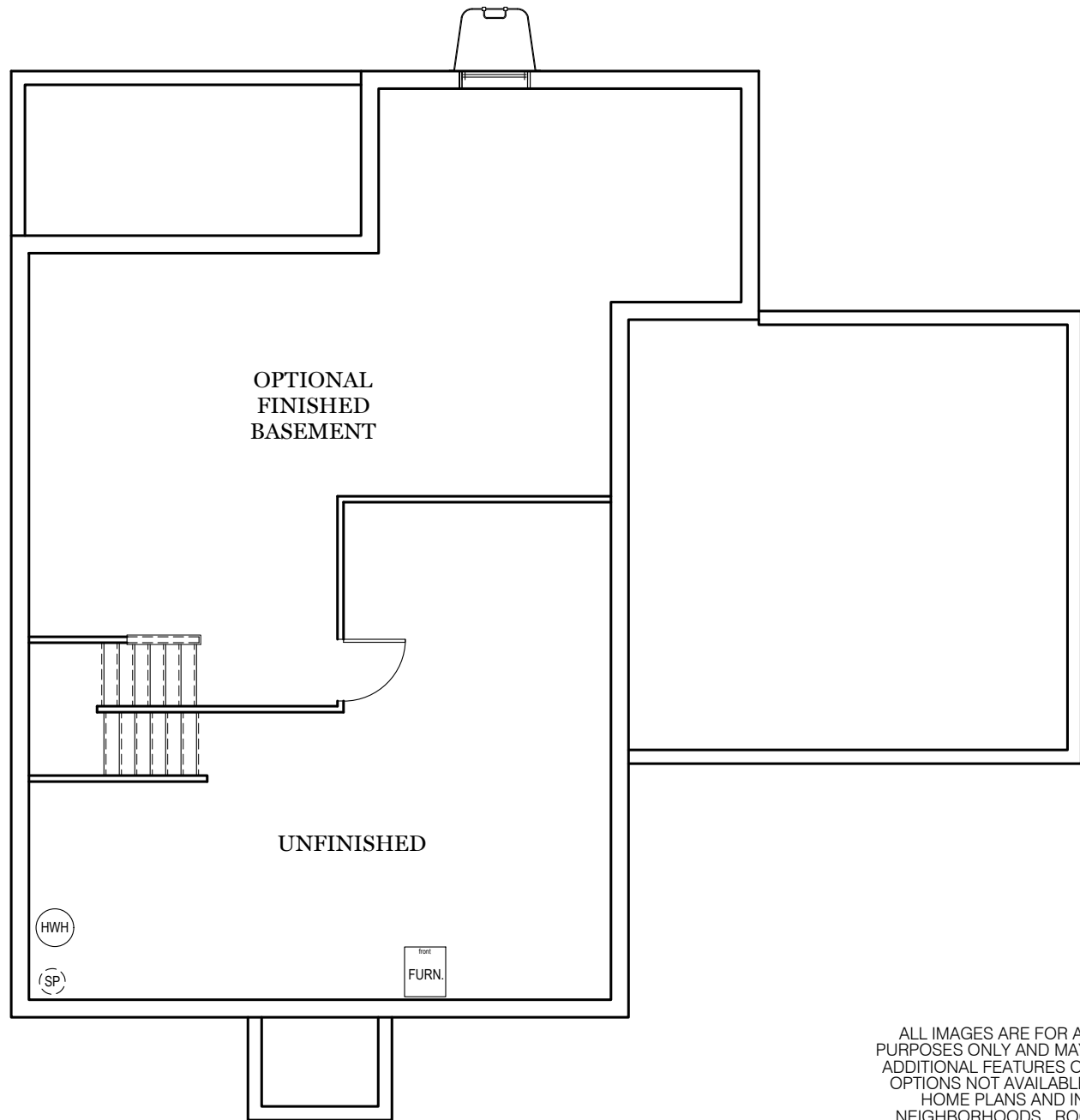



OPTIONAL EXTENDED COVERED PORCH



TRADITIONAL ELEVATION\*\*



CLASSIC ELEVATION

ALL IMAGES ARE FOR ARTISTIC PURPOSES ONLY AND MAY CONTAIN ADDITIONAL FEATURES OR DESIGN OPTIONS NOT AVAILABLE ON ALL HOME PLANS AND IN ALL NEIGHBORHOODS. ROOM SIZE DIMENSIONS AND SQUARE FOOTAGES ARE APPROXIMATE. CONTACT SALES AGENT FOR MORE INFORMATION. TERMS AND CONDITIONS APPLY. [HTTPS://EGSTOLTZFUSHOMES.COM/TERMS-AND-CONDITIONS/](https://egstoltzfushomes.com/terms-and-conditions/)



OPTIONAL EXTENDED COVERED PORCH



AMERICAN ELEVATION



HERITAGE ELEVATION

ALL IMAGES ARE FOR ARTISTIC PURPOSES ONLY AND MAY CONTAIN ADDITIONAL FEATURES OR DESIGN OPTIONS NOT AVAILABLE ON ALL HOME PLANS AND IN ALL NEIGHBORHOODS. ROOM SIZE DIMENSIONS AND SQUARE FOOTAGES ARE APPROXIMATE. CONTACT SALES AGENT FOR MORE INFORMATION. TERMS AND CONDITIONS APPLY. [HTTPS://EGSTOLTZFUSHOMES.COM/TERMS-AND-CONDITIONS/](https://EGSTOLTZFUSHOMES.COM/TERMS-AND-CONDITIONS/)